

Ezy-Drink® CP-BS Lead Safe™ Horizontal Lever Action Drinking Bubbler Tap Fi

PRODUCT CODE:

- 170.50.14.00

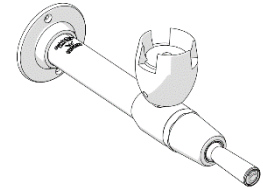

SPECIFICATIONS

- Drinking taps are designed to operate at full mains pressure.
- Rubber mouthguard is designed to help protect teeth when drinking.
- Rubber mouthguard is resistant to fungal and bacterial attack and has a high resistance to sunlight.
- Adjustable built-in flow restrictor.
- Made from Lead Safe™ DR Brass*

IMPORTANT: All Ezy-Drink® Lever Bubbler taps are tested in accordance with AS/NZS 3718 and leave our premises in good working order.

*Our Lead Safe™ product range is compliant with the Lead Free Requirements of the NCC 2022 Vol. Three, Clause A5G4(2) and NSF/ANSI 372.

WARNINGS: Special attention to be paid on notes, photos, images, or drawings of assembly steps marked with the warning symbol.



TECHNICAL DATA

Inlet	Rp 1/2"	
Outlet	Rubber mouthguard	
Headwork	Lever action	
Working Pressure Range (kPa)	Min	50
	Max	500
Working Temperature Range (°C)	Min	5
	Max	60
Nominal Flow Rate (LPM)	1.7	
Finish	Chrome	

NOTE: Galvin Engineering continually strives to improve their products. Specifications may change without notice.

TOOLS REQUIRED

- Power drill
- Spanner or adjustable crescent
- Screwdriver

PRE-INSTALLATION - MOUNTING DETAILS

- If the mounting holes do not already exist, mark out and drill the holes in the wall/sheet, as shown in rough-in dimensions.

⚠ Note: Before installation, all lines must be flushed. We recommend that a line strainer be installed prior to drinking taps to eliminate any foreign material.

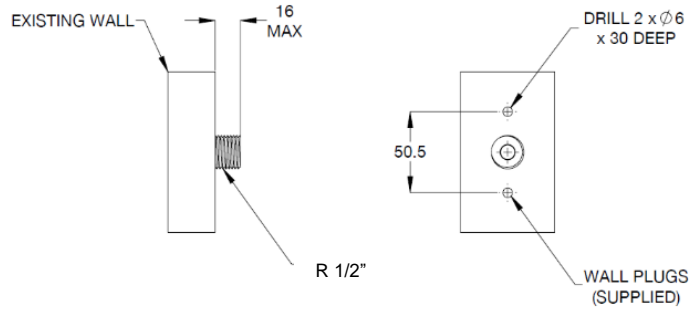

⚠ Rough-in Dimensions

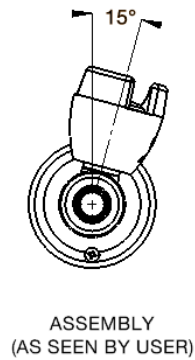
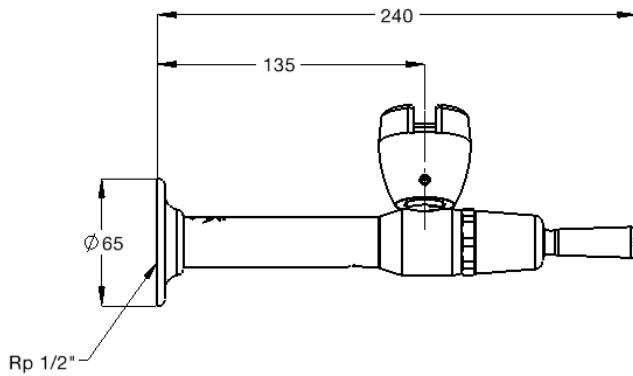

INSTALLATION

IMPORTANT: Galvin Engineering products must be installed in accordance with these installation instructions and in accordance with AS/NZS 3500, the PCA and your local regulatory requirements. Water and/or electrical supply conditions must also comply to the applicable national and/or state standards. Failing to comply with these provisions shall void the product warranty and may affect the performance of the product.

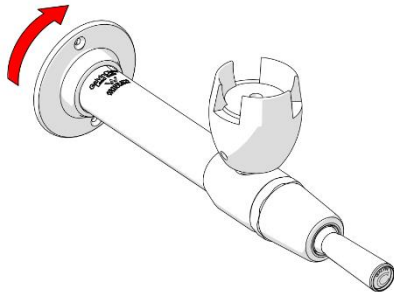

1. Fit tap assembly

- Fit wall plugs to wall as per rough-in dimensions.
- When applying thread tape or sealant to the inlet, ensure the opening is not obscured. Failure to do so may restrict or block the flow restrictor, affecting the flow of water.
- Screw tap onto existing spud until the flange is touching the wall.
- Ensure the mouthguard is in the correct position and the holes in the flange align with the wall plugs.

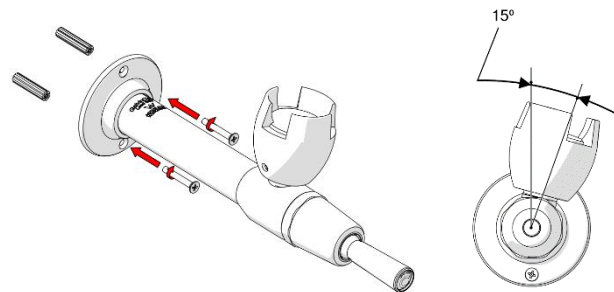

2. Secure the body

- Secure the body with supplied screws.

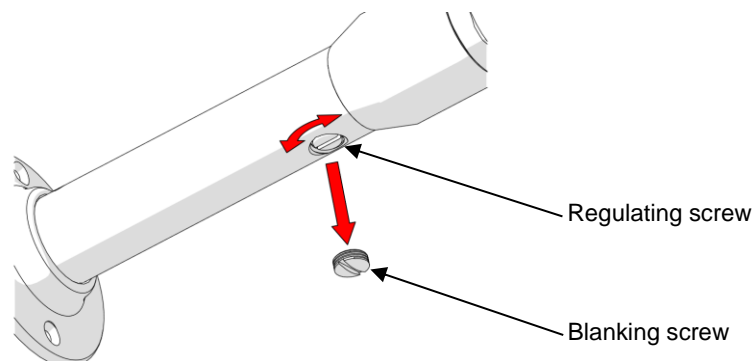

3. Testing

- Once the drinking tap has been installed and tested for leaks, the water height may be adjusted to suit the available pressure.
- To adjust water flow
 1. Remove the blanking screw
 2. Adjust the water height by turning the regulating screw
 3. Replace blanking screw



Note: The full range from minimum flow to maximum flow is only ¼ turn

TROUBLESHOOTING		
PROBLEM	CAUSE	RECTIFICATION
Inconsistent flow	Blocked top assembly or regulating screw	Remove top assembly and/or regulating screw and clean
Water is not flowing from tap	Water is turned off	Turn on water
	Blocked regulating screw	Remove regulating screw and clean
Continuous flow	Top assembly loose or internally obstructed or damaged	Remove top assembly, clean with water and regrease spindle if required
Rate of flow inadequate	The flow regulator screw may not be adjusted correctly	Remove blanking screw and adjust flow regulating screw as described

WARRANTY
<p>Galvin Engineering products are covered under our Manufacturer's Warranty. Galvin Engineering products must be installed in accordance with the installation instructions and in accordance with AS 3500 and NCC Volume Three, relevant Australian Standards and local authorities applicable to product being installed. Water and electrical supply conditions must also comply to the applicable national and/or state standards, failing to comply with these provisions may void the product warranty and affect performance of the product.</p> <p>Please visit www.galvinengineering.com.au to view the full warranty, our Installation Compliance and Maintenance & Cleaning information as well as any other additional information.</p>